

Isokell Installation and general recommendations

Storage:

Storage space for **2 frames** (see below) and **3 adapters** (see below):

- For sample size 1.2 x 1.0 m:
 - Adapter: 151 x 191 x 41 cm*, ≈120 kg
 - Frame: 165 x 215 x 6 cm*, ≈150 kg
- For sample size 1.0 x 1.8 m:
 - Adapter: 151 x 191 x 41 cm*, ≈120 kg
 - Frame: 165 x 215 x 6 cm*, ≈150 kg
- For sample size 1.543 x 2.043 m:
 - Adapter: 154 x 204 x 47 cm*, ≈120 kg

*[LxWxH]

The storage can possibly be done in a shelf construction. Each item above has the possibility to mount 4 eye-screws in each corner for easy handling with a crane. The insertion floor can be stored horizontal or vertical.

A crane (minimum 350 kg) movable in both x-y is needed.

A stair or stepladder is needed [examples, not included in the standard Isokell]:



Or a costumed stair (example, can be offered)

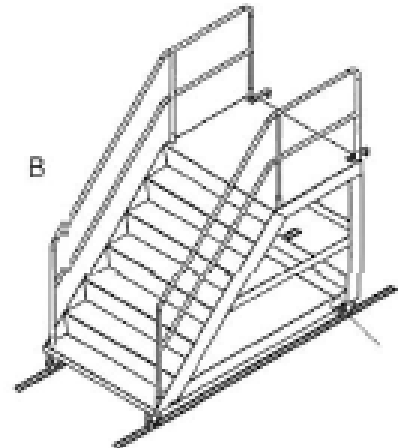

Please note that local safety standards must be considered.

Compressed air supply

A supply of compressed air (minimum pressure 4.5 bar), with an appropriate pressure gauge for control purposes, are required for the operation of the integrated pneumatic lifting device. **This air supply is not included in the system**

Room requirements:

The floor surface where the Isokell should be placed must be even, smooth and in level. A tolerance of maximum +/- 5 mm over the surface is allowed.

Maximum back ground noise level maximum 75dB(A) [over all]

The Isokell should be placed in a room with low noise and vibrations levels. It is an advantage if the walls and ceiling is (partly) covered by absorbing materials in order to reduce the noise level in the room.

In order to avoid malfunctions and damages of the electronics, the operative conditions of the system must not exceed the below ranges

- **Temperature: 10°C to 35°C**
- **Relative Humidity: 20% to 80% noncondensing**

Transport / Handling

The Isokell is delivered at the customer site on 4 wooden pallets wrapped in cardboard box.

- Isokell housing: 3.66 x 2.54 x 2.05 m*, ~1'220kg
- Isokell trolley: 3.30 x 2.42 x 1.85 m*, ~2'106kg
- Alpha Cabin: 3.22 x 2.37 x 2.03 m*, ~1'950kg
- Adapters and frames: 2.20 x 1.70 x 1.15 m*, ~640kg

*[LxWxH]



In order to handle the different packages of Isokell it is normally requested to use a forklift with forks of at least 1.5m length or a lifting device (e.g. crane or fork lift with crane attachment), in both cases the lifting device must be able to lift at least 2000kg.



Positioning of the Alpha Cabin on the Isokell lower chamber (during installation):

One lifting device (e.g. crane or fork lift with crane attachment) at the loading ramp (or temporary storage room) and the final Isokell room is needed. The lifting device must be able to lift to a height of 4.20m with 1100kg capacity

The Isokell is 3.40m height and during the installation the Alpha Cabin must be lifted 10-15 cm over the edge in the Isokell lower chamber. The Edge is about 15cm, and the height of the Alpha Cabin during the lift is then $3.4 + 0.65 + 0.15 = 4.20\text{m}$.

Forklift:

If a fork lift is used, the length of the forks must be minimum 1.50m. (to be able to load/position the cabin from the side, from the front even longer forks are needed).

This is most probably not possible and a special fork crane is needed, see pictures:



If a crane (1100kg) is available in the Isokell room, only a lifting device on the off-loading place is needed.

Crane:

The lateral eyelets on the Isokell can be used for lifting up the system by means of special belts (included in the system). See picture below:

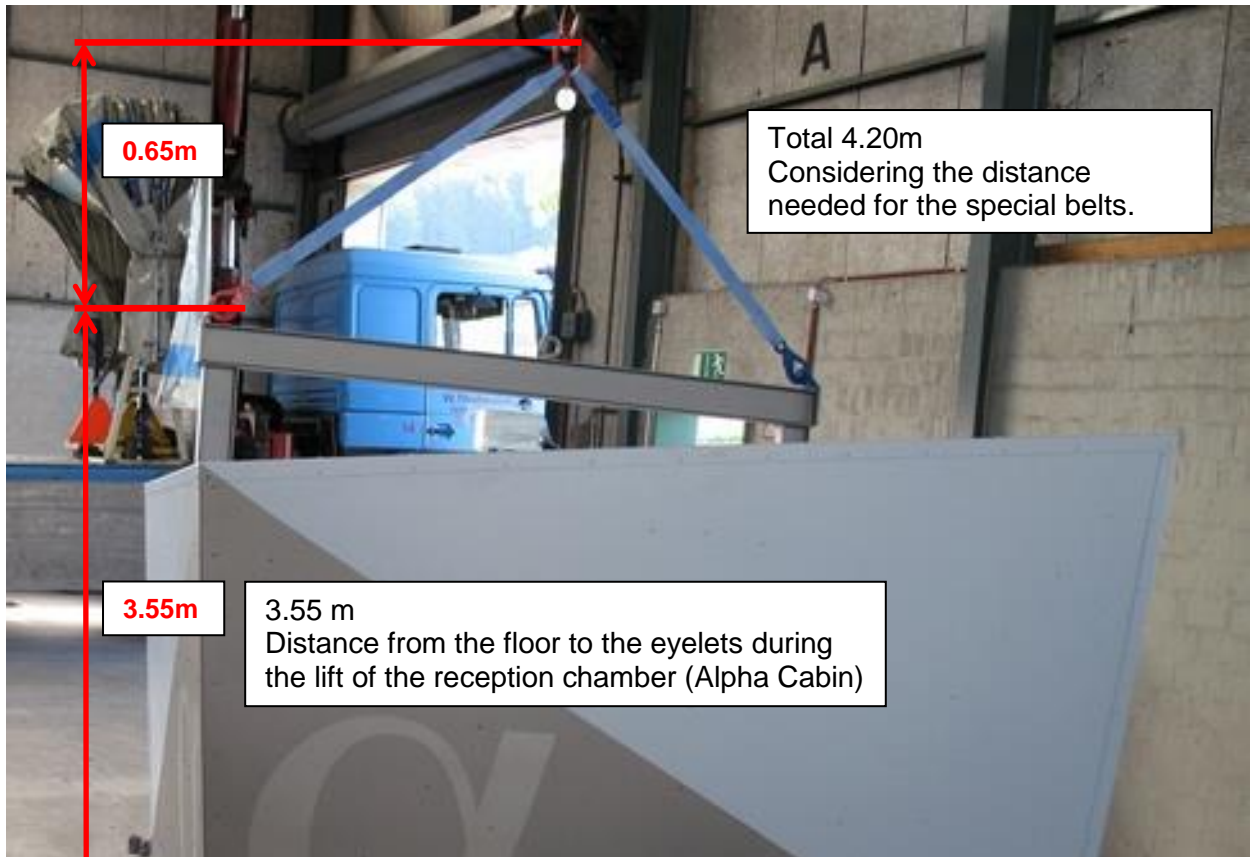

If the lateral eyelets cannot be used, it is still possible to use the central eyelet on the Isokell beam. In this case it must be connected to the crane hook, or the side eyelet to the crane hook. To fix the hook to the Isokell centre beam eyelet we estimate that about 20-30 cm is needed, see picture

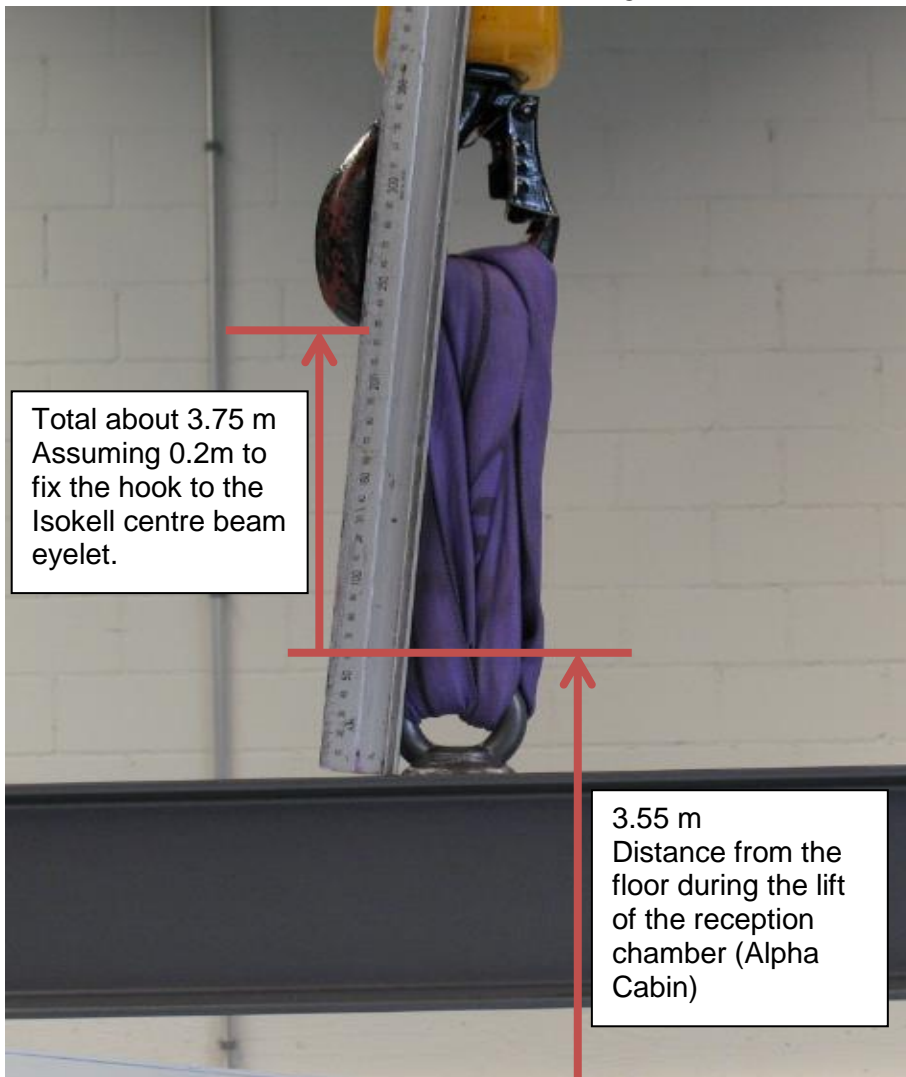

This means that the distance from the floor to the crane hook in the upper position should be minimum 3.75m.

The distance from the crane hook to the ceiling depends on the crane type and construction.

Dimensions of the Isokell (L x W x H):

Overall dimensions of lower housing 3.40 x 2.50 x 1.70 m

Total Height including the Alpha Cabin about 3.40 m (+0.80m space for positioning the Alpha Cabin)

Dimensions of the excitation chamber 3.30 x 2.36 x 1.55 m

Installation of Autoneum Isokell - Layout examples

A minimum room size is about 12 x 9 meters gives a comfortable workspace. However other solutions are possible.

When working only with the Isokell a space of about 9 x 8 meters is enough.

Layout example (With Alpha Cabin floor):

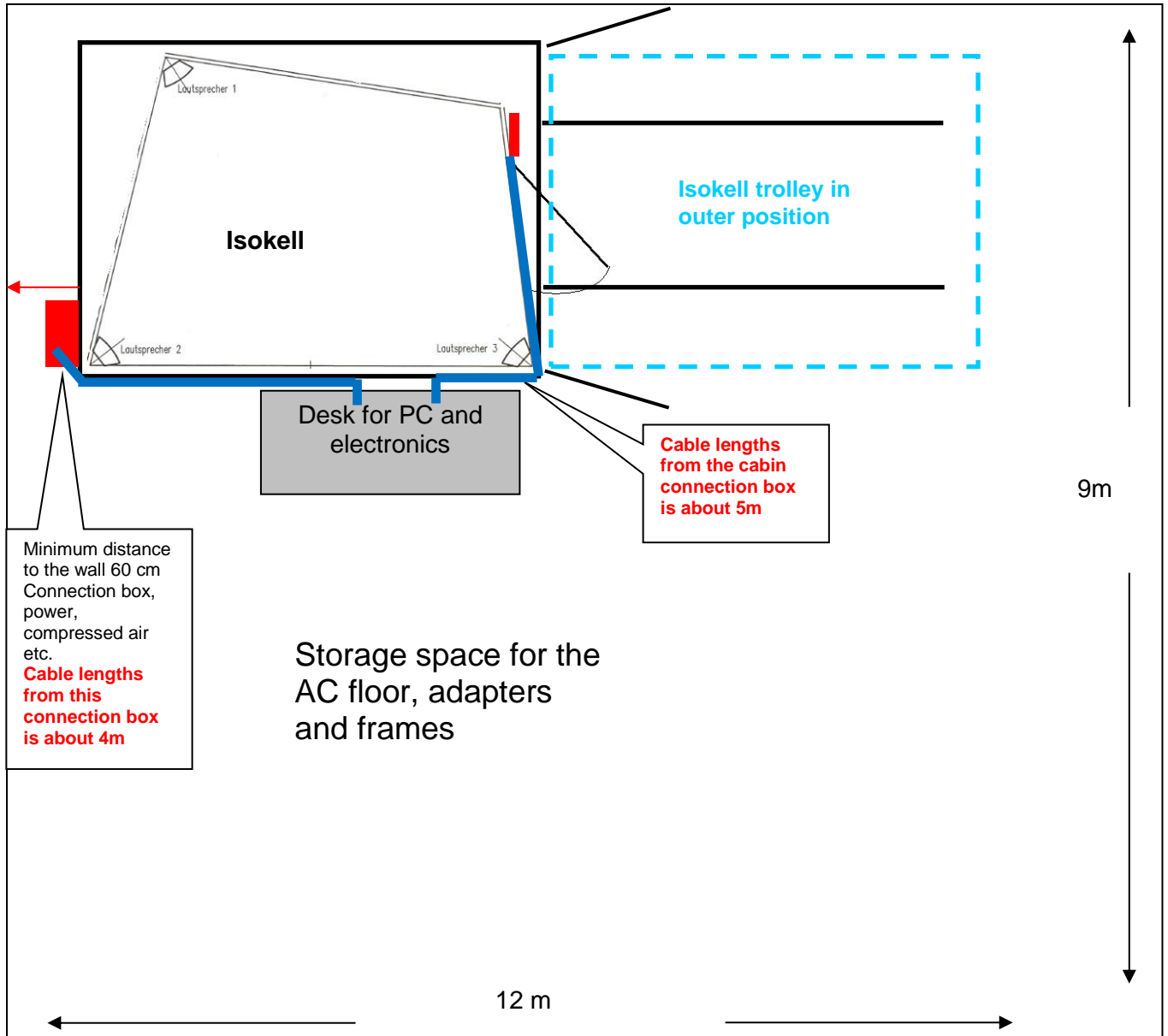

Main data of the Isokell**Physical dimensions**

Overall dimensions 3.4 x 2.5 x 3.4 m (L x W x H)
*(+0.80m space for positioning the Alpha Cabin + space for a crane)

Total weight including the Alpha Cabin about 3800 kg

Emission Chamber

Volume of the chamber ~ 2.0 m³, depending on sample

Overall dimensions of lower housing (in operation) 3.4 x 2.5 x 1.7 m (L x W x H)

Total weight without the Alpha Cabin about 2730 kg

Sample Aperture:
1.0m x 1.2m (standard flat samples)
1.0m x 1.8m (dash-boards)
1.5m x 2.0m (dash-boards or larger parts)

Maximum Sample Depth: 0.55m

Alpha Cabin (reception chamber)

Volume of cabin: ~ 6.9 m³, depending on sample

Interior surface area: ~ 23.5 m², depending on sample

Overall dimensions of cabin (without floor) 3.22 x 2.37 x 2.03 m (L x W x H)

Weight of the cabin (without floor) 1070 kg

Power Requirements

230V, 50Hz, 110V, 60Hz
(Other mains voltages and frequencies are available on request)

1000 W Power consumption (complete system including PC and screen)

Environment Requirements for Electronics

Temperature 10°C to 35°C

Relative Humidity 20% to 80% noncondensing

General

Measurement frequency range
1/3 octave bands 0.125 to 6.3 kHz

Emission Chamber

Acoustic Excitation 6 Loudspeakers, LF/HF 700/180W each

No. of microphone positions 5

Alpha Cabin (reception chamber)

Acoustic excitation 3 Loudspeakers, 8 Ω, 50 W

No. of microphone positions 5

Installation Isokell 25.04.2017